

Parts List			
ITEM	QTY	PART NUMBER	DESCRIPTION
1	1	LSTM050H	1/2" NPT MINI T-STRAINER HEAD
2	1	LSTM050G	MINI T-STRAINER GASKET
3	1	LST550	1/2" LST SCREEN - 50 MESH
4	1	LSTM050BC	MINI T-STRAINER CLEAR BOWL

**Note:**  
Additional Clearance Req'd  
for screen removal: 2 3/4"

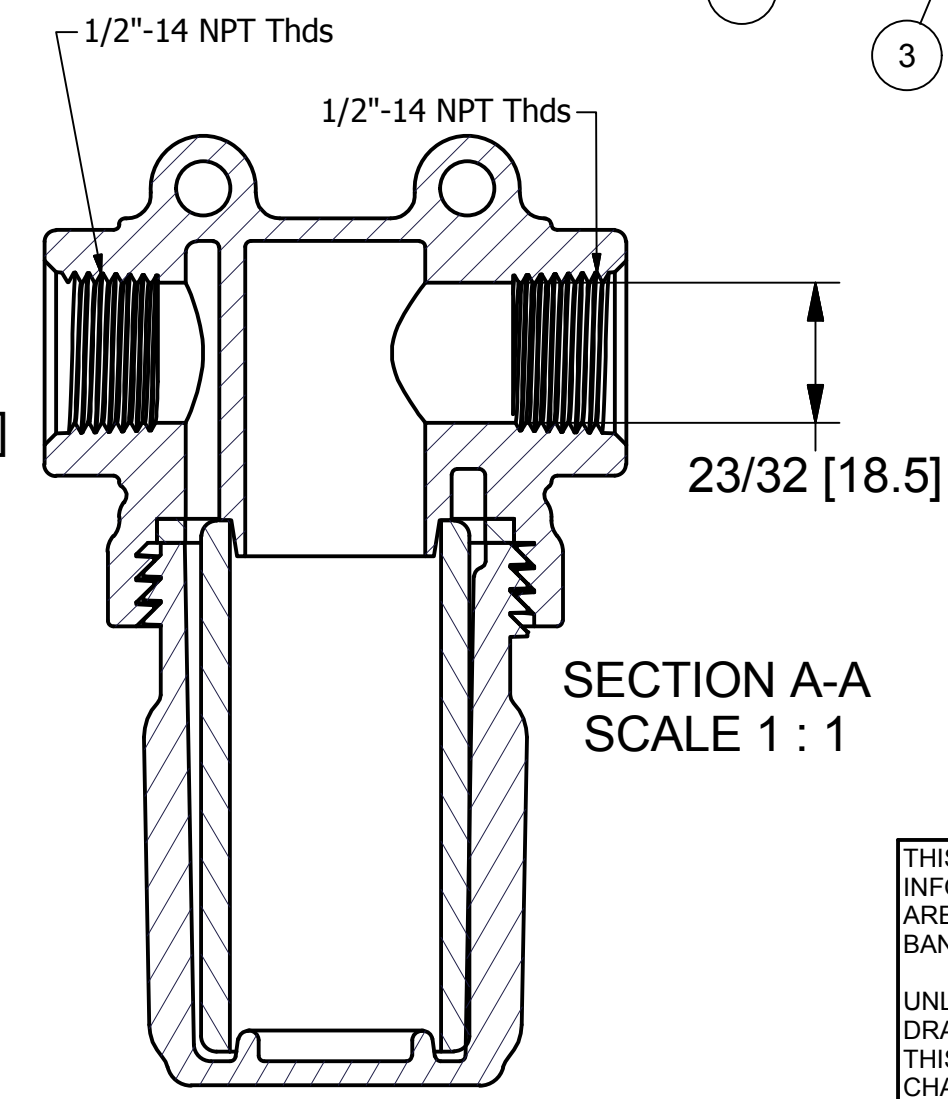
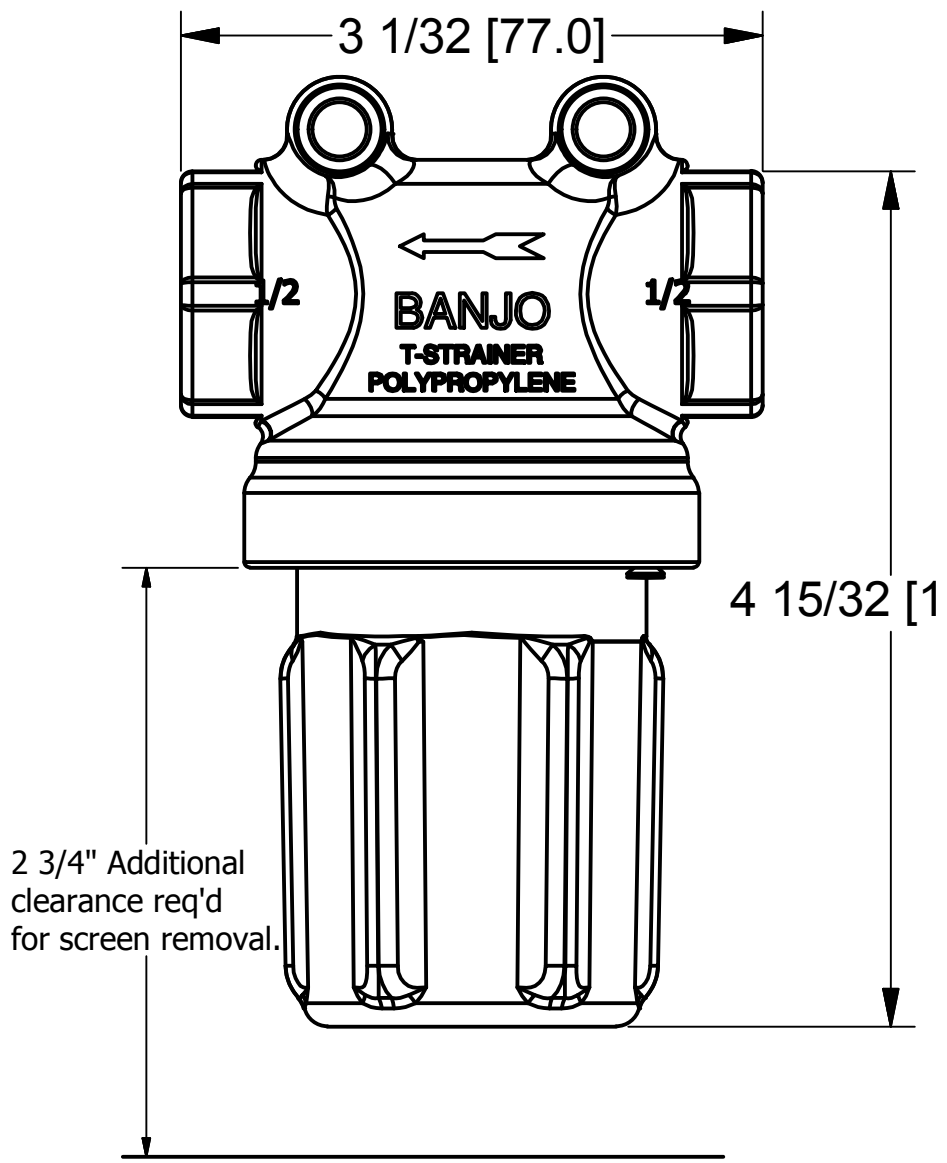

THIS DRAWING AND ALL INFORMATION CONTAINED THEREON ARE THE EXCLUSIVE PROPERTY OF BANJO CORPORATION.

UNLESS SPECIFICALLY NOTED, THIS DRAWING AND ITEMS SHOWN ON THIS DRAWING ARE SUBJECT TO CHANGE AT ANY TIME.



**BANJO CORPORATION**

150 BANJO DRIVE, CRAWFORDSVILLE, IN 47933  
 WEB SITE: WWW.BANJOCORP.COM  
 E-MAIL: BANJOSALES@IDEXCORP.COM

DESCRIPTION	1/2" T-Strainer w/ Clear Bowl - 50 Mesh
PART NUMBER	LSTM050-50C

4

3

2

1

4

3

2

1